

# Rebound of a Coal Tar Creosote Plume following Partial Source Zone Treatment with Permanganate

Neil Thomson, Michelle Fraser, Coby Lamarche, Jim Barker, Steve Forsey

University of Waterloo

Waterloo, Ontario

Canada N2L 3G1

University of  
**Waterloo**



# Background

---

Management of dissolved phase plumes from coal tar creosote contaminated sites is a technical challenge..

- 100's of different compounds
- origin of the coal
- distilling process

85% aromatic hydrocarbons

10% phenolic compounds

5% N-S-O heterocyclics

# Potential Remedy

---

When contaminant mass removal is not primary remedial goal...

look at source zone stabilization methods

Reduction of permanganate ...

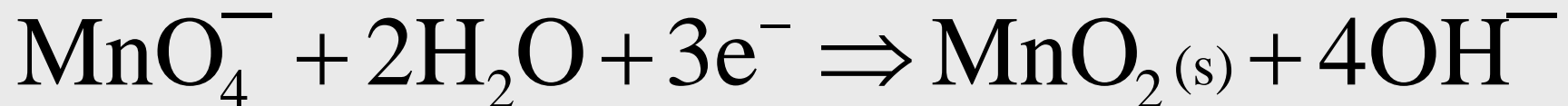

# Manganese Oxides

---

- form at the point of reaction
- highly insoluble
- aggregate to form colloids

Precipitation of these solids has been shown to:

- decrease hydraulic conductivity
- cause flow divergence
- reduce post-treatment mass transfer



# Research Objective

---

The potential of partial permanganate treatment to reduce the ability of a coal tar creosote source zone to generate a multi-component plume at the pilot-scale...



- short-term (weeks to months)
- long-term (years)

# Approach

---

- **bench-scale experiments**
  - kinetics
  - post-treatment mass load
- **pilot-scale (10 years plume data)**

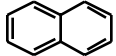
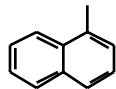
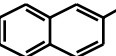
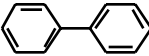
# Reactivity Kinetic Data

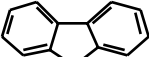
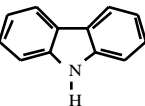
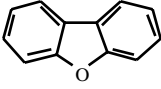
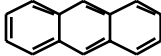
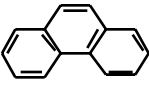
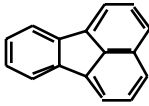
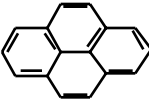
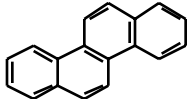
Compound	Formula	Structure	T <sub>1/2</sub> [min]
naphthalene	C <sub>10</sub> H <sub>8</sub>		1000
1-methylnaphthalene	C <sub>11</sub> H <sub>10</sub>		800
2-methylnaphthalene	C <sub>11</sub> H <sub>10</sub>		600
biphenyl	C <sub>12</sub> H <sub>10</sub>		NR
acenaphthene	C <sub>12</sub> H <sub>10</sub>		50
fluorene	C <sub>13</sub> H <sub>10</sub>		25
carbazole	C <sub>12</sub> H <sub>9</sub> N		25
dibenzofuran	C <sub>12</sub> H <sub>8</sub> O		NR
anthracene	C <sub>14</sub> H <sub>10</sub>		<2
phenanthrene	C <sub>14</sub> H <sub>10</sub>		30
fluoranthene	C <sub>16</sub> H <sub>10</sub>		10
pyrene	C <sub>16</sub> H <sub>10</sub>		5
chrysene	C <sub>18</sub> H <sub>12</sub>		900



not reactive

fast

# Bench-Scale Effort

- 3% (v/v) creosote
- initial water flush
- 7 days permanganate flush
- post-treatment water flush

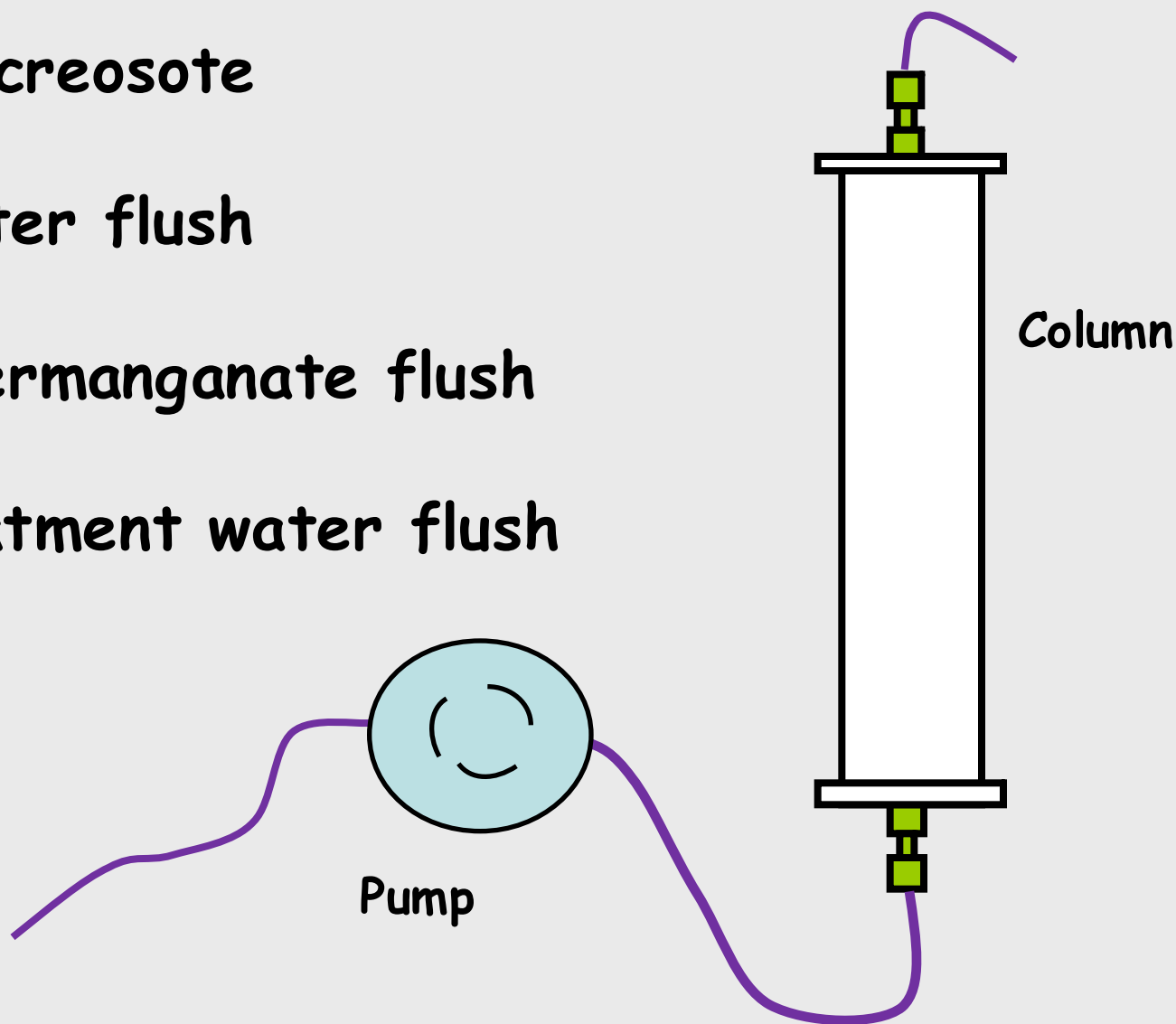

# Bench-Scale Effort

Compound	MW [g/mol]	Aqueous Solubility [mg/L]	Mass Fraction [%]	Percent Change
naphthalene	128.2	31.7	8.1	-14
indole+2-methylnaphthalene	142.2	24.4	3.9	-26
1-methylnaphthalene	142.2	28.5	1.8	-29
acenaphthylene	152.2	-	0.2	-76
biphenyl	154.2	7.5	1.5	92
acenaphthene	154.2	3.9	6.0	-55
fluorene	166.2	2	4.7	-65
carbazole	167.2	1	0.87	-97
dibenzofuran	168.2	10	4.0	44
phenanthrene	178.2	1.3	10.4	-52
anthracene	178.2	0.07	1.1	-60
fluoranthene	202.3	0.26	5.2	41
pyrene	202.3	0.14	4.0	-81
Total:			51.8	-25

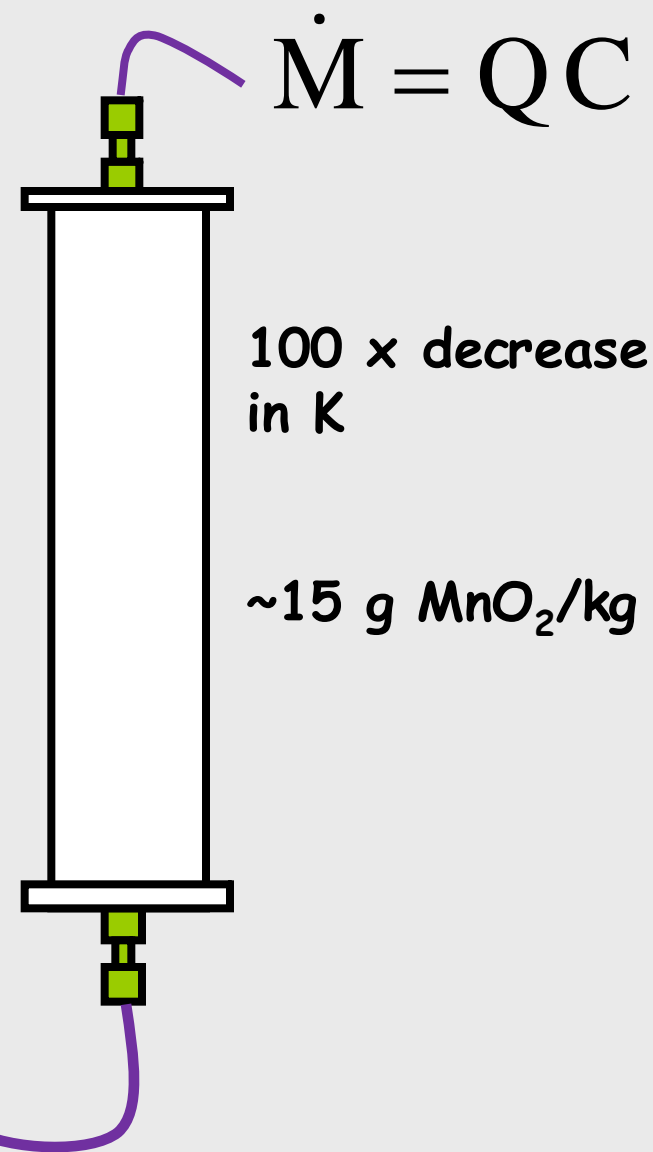

# Pilot-Scale

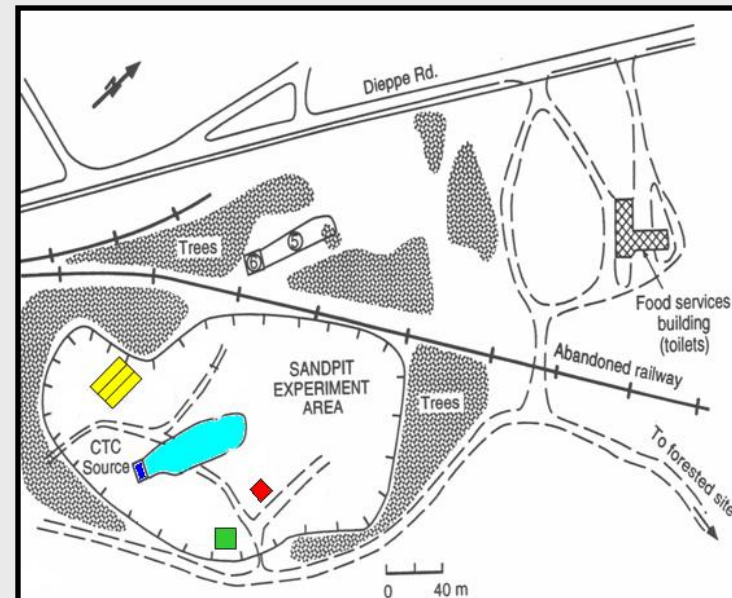
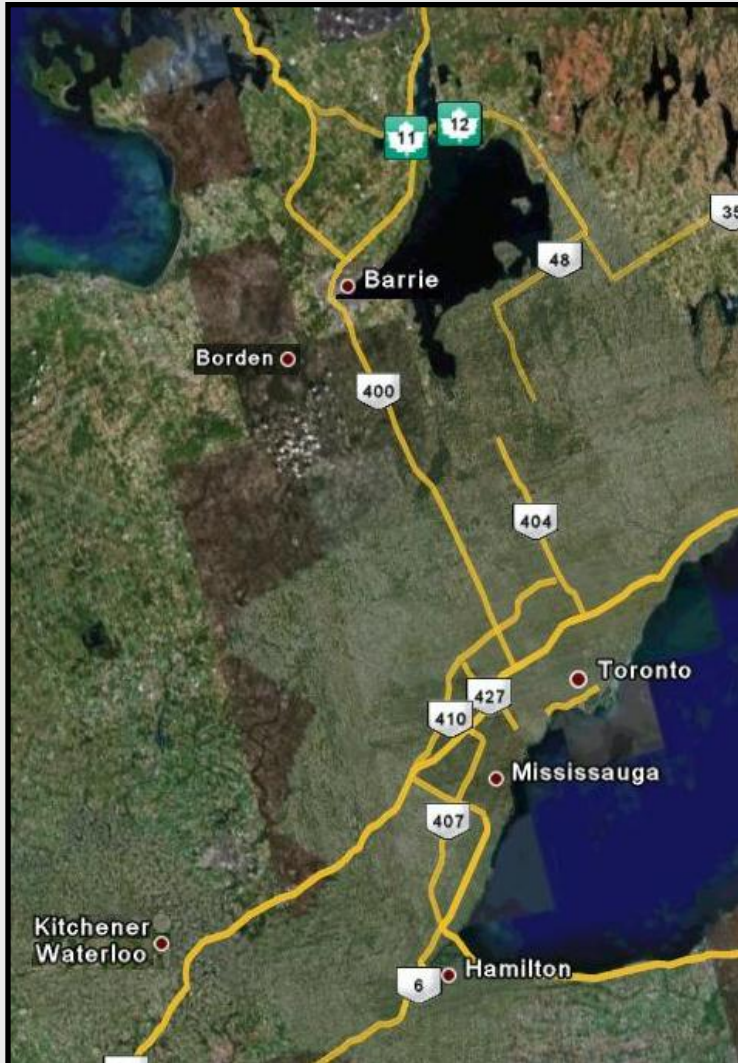

Porosity:	0.33
Bulk Density:	1.81 g/cm <sup>3</sup>
Hydraulic Conductivity:	7x10 <sup>-5</sup> m/s
Depth to Water Table:	varies, 0 - 1.5 mbgs
Hydraulic Gradient:	mean 0.0039
Groundwater Velocity:	0.091 m/day

# Pilot-Scale

---

74 kg of coal tar creosote was  
emplaced below the water table in  
August 1991 (Year 0)

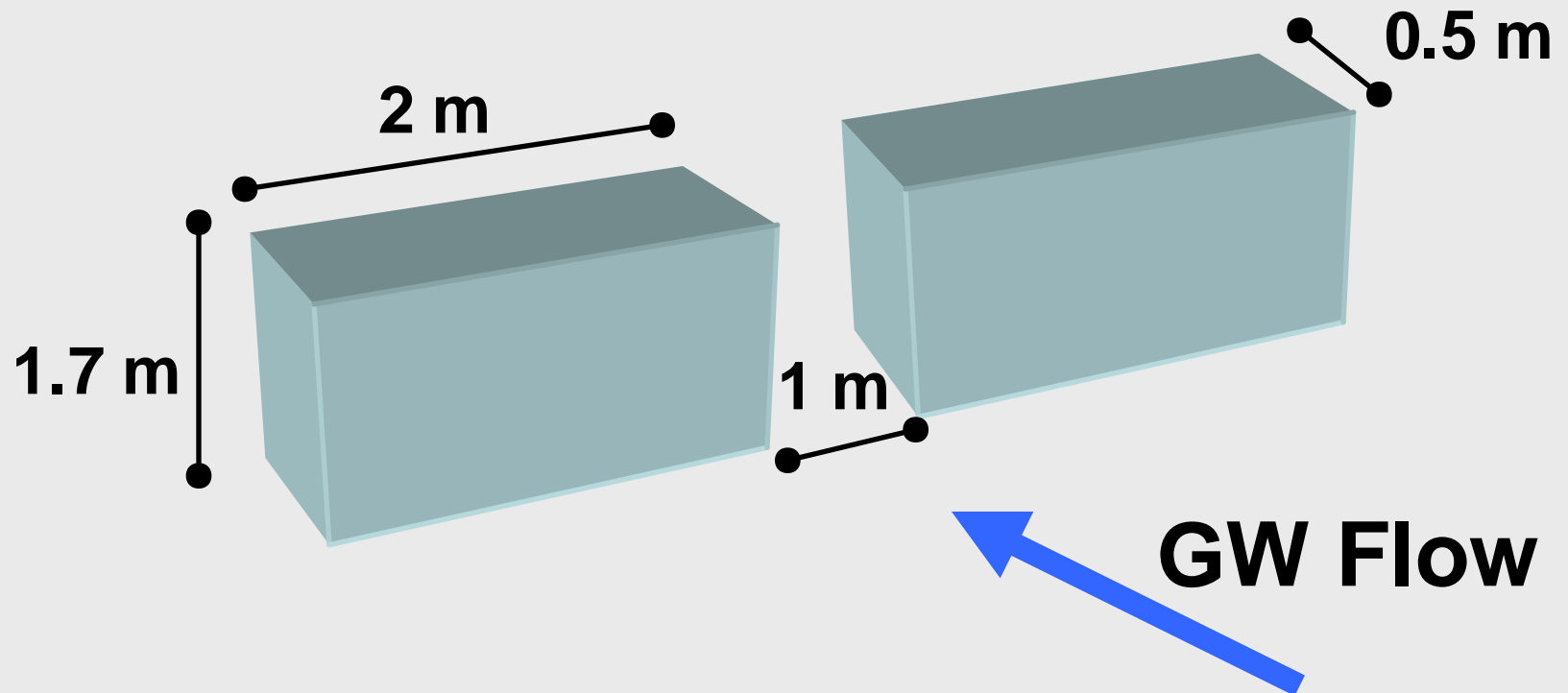

# Initial Plume Monitoring

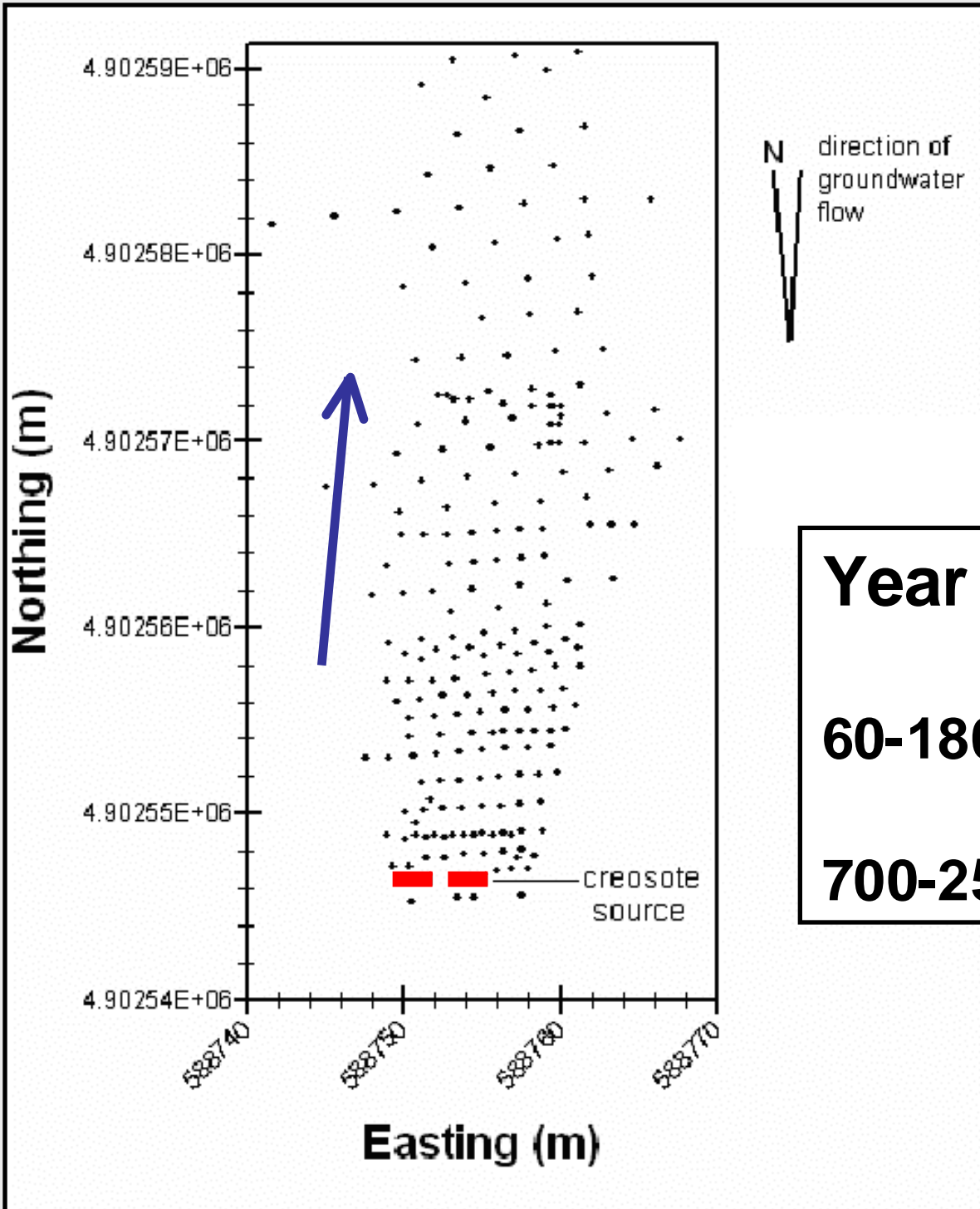

**Year 1, 2, 4, 10**

**60-180 multilevel wells**

**700-2500 samples/episode**

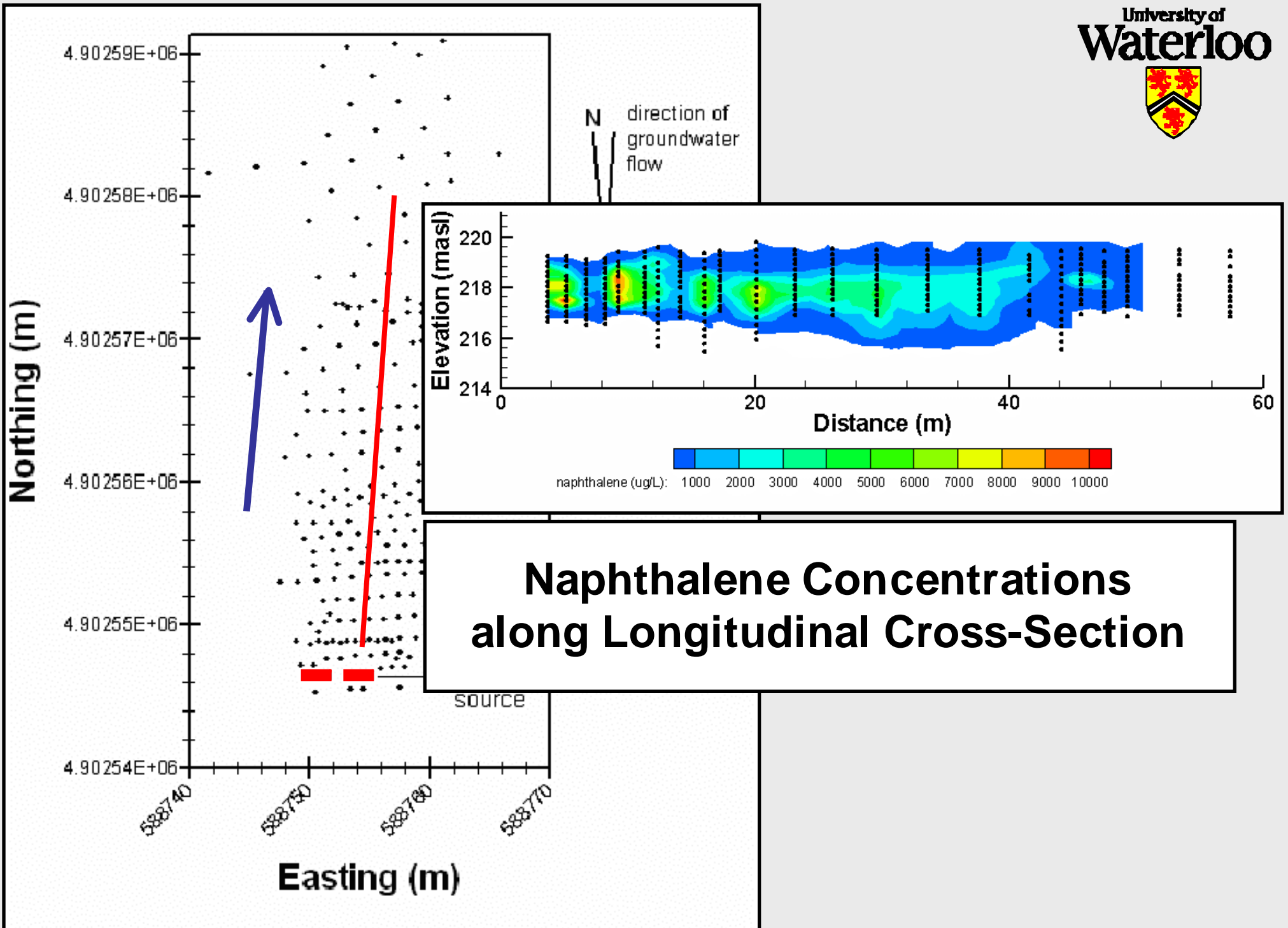

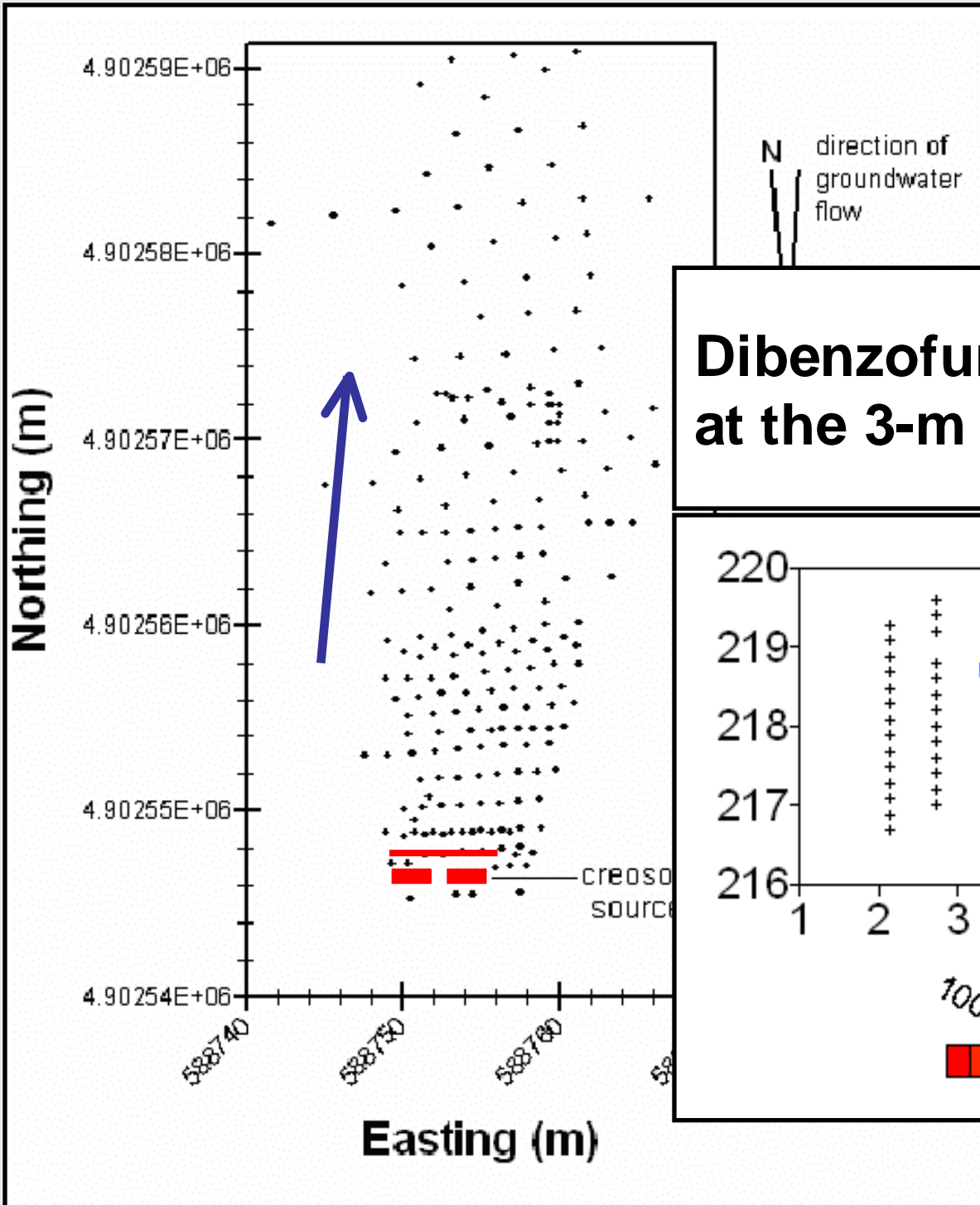

## Dibenzofuran Concentrations at the 3-m Fence line

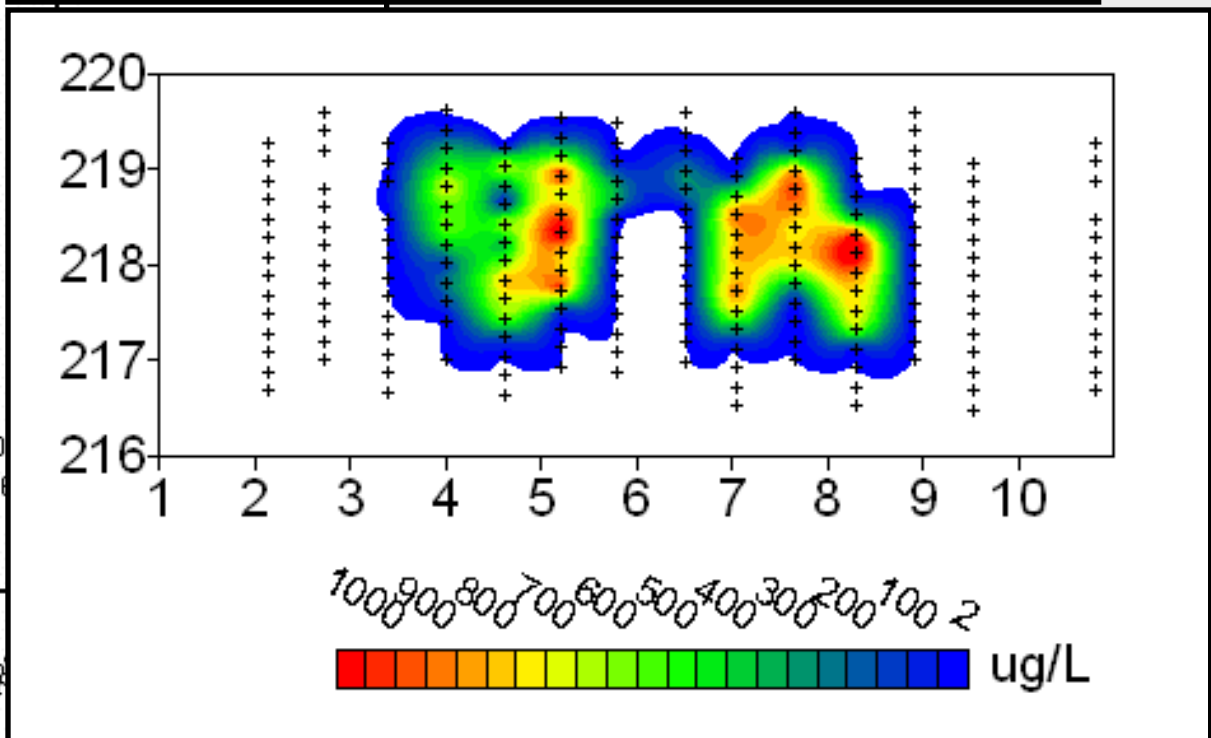

# Mass Loading

$$\dot{M} = \int q C dA$$

## Naphthalene

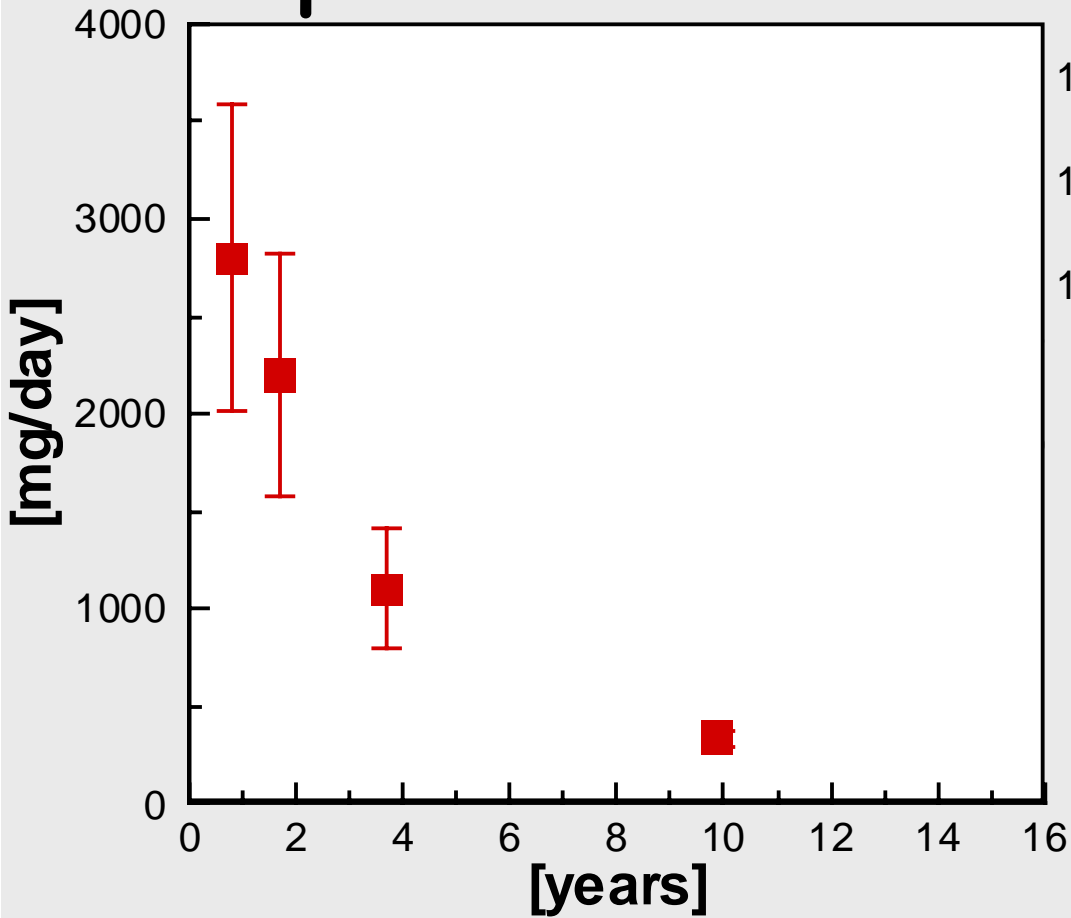

## Dibenzofuran

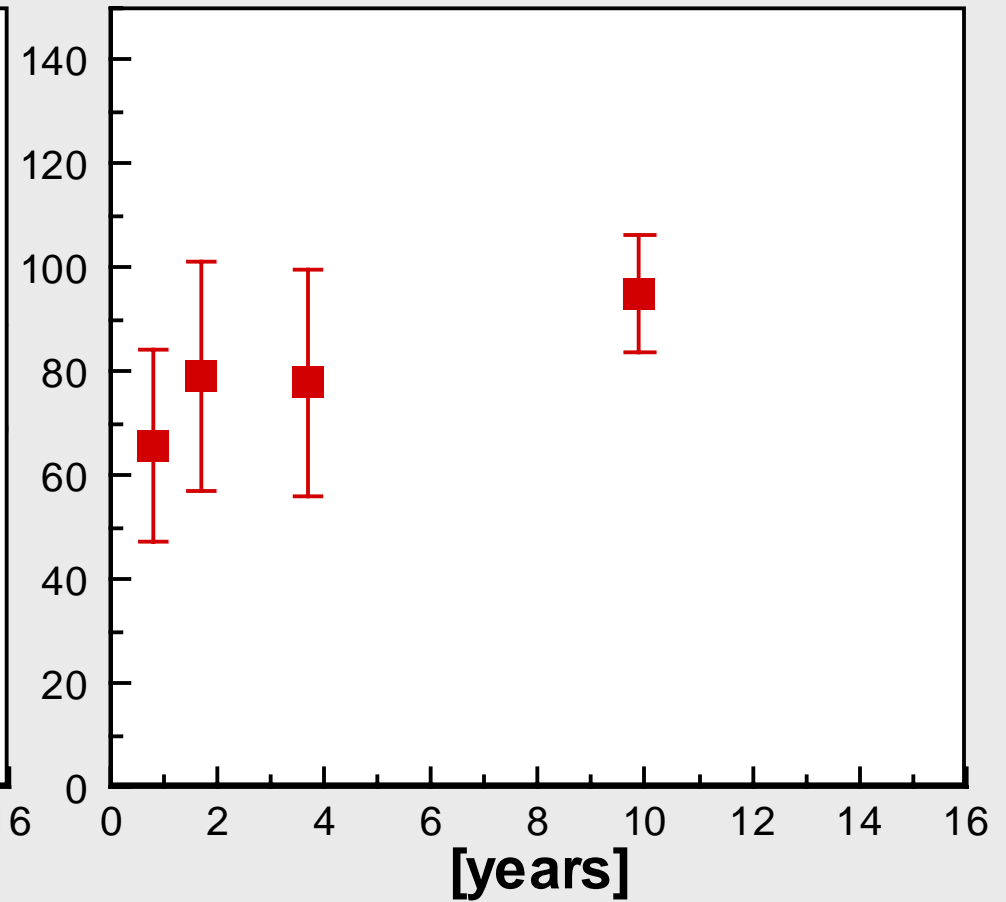

# Source Zone Treatment

---

- semi-passive pulse injection system

# Semi-Passive Pulse Injection Concept

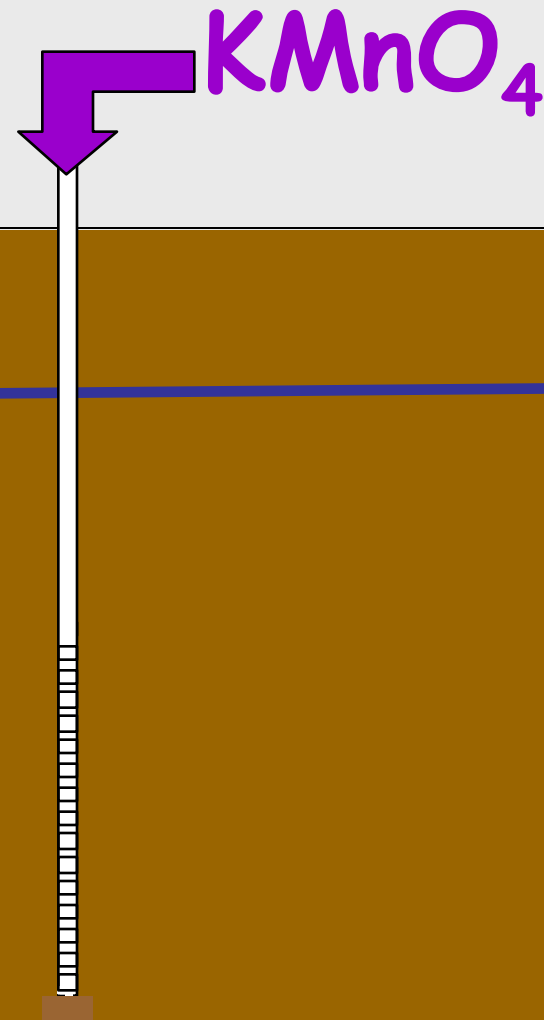

# Semi-Passive Pulse Injection Concept

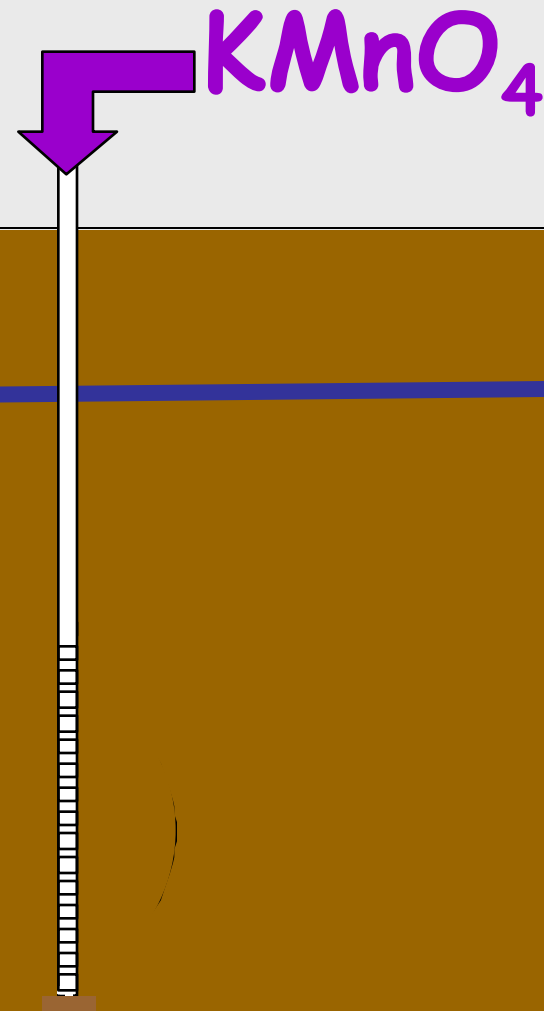

# Source Zone Treatment

---

- semi-passive pulse injection system
- 3200 L of 15 g/L per episode
- 7-day intervals
- monitored hydraulics and permanganate breakthrough down gradient
- 6 episodes / 125 kg
- ~ 20 pore volumes
- ~35% of estimated reactive compounds

# Source Zone Treatment

## Permanganate

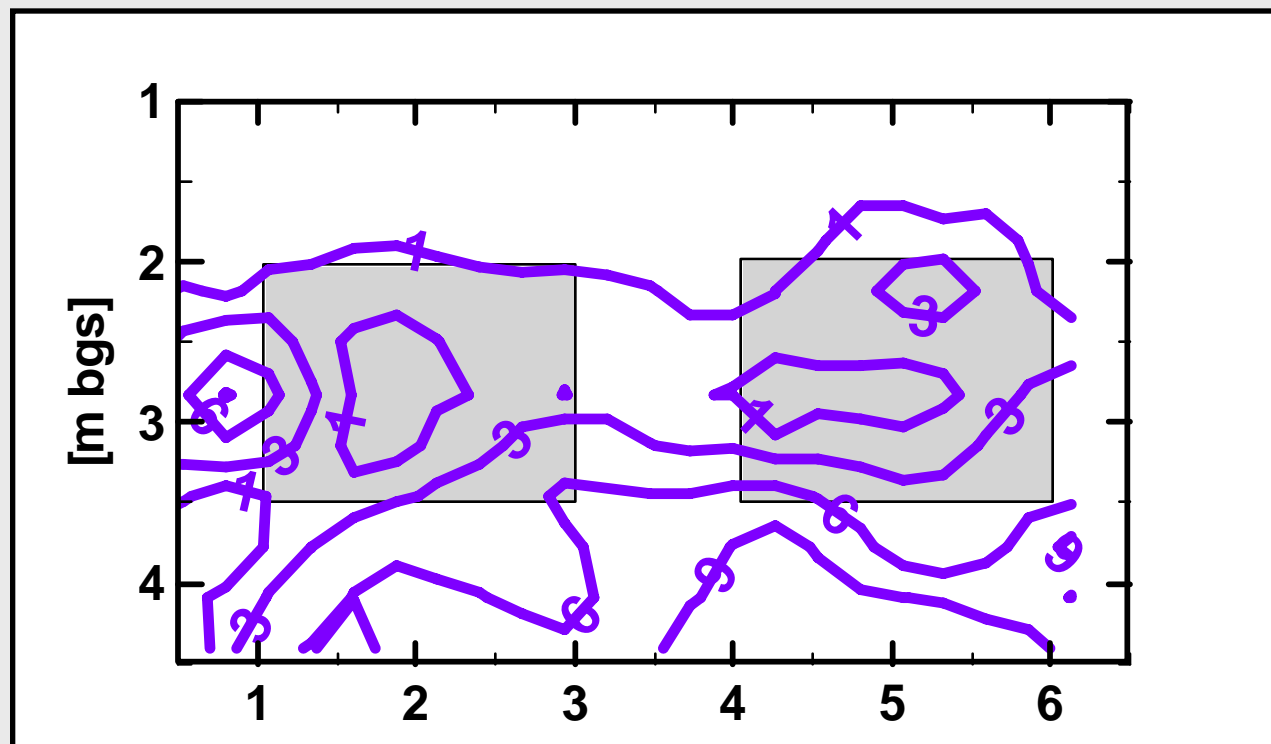

(7 days after 3<sup>rd</sup> injection)

# Short-Term Monitoring

Compound	Pre [mg/day]	Post [mg/day]	Percent Change
naphthalene	750	310	-59
1-methylnaphthalene	200	120	-40
acenaphthylene	15	6	-58
biphenyl	84	71	-15
acenaphthene	430	200	-53
fluorene	110	51	-54
carbazole	61	18	-70
dibenzofuran	250	210	-16
phenanthrene	96	60	-37
anthracene	31	14	-55
fluoranthene	13	11	-11
pyrene	9	3	-63
<b>Total</b>	<b>2048</b>	<b>1075</b>	<b>-47</b>

Changes in  
mass load  
at fence line  
150 days  
after  
treatment

$$\dot{M} = \int q C dA$$

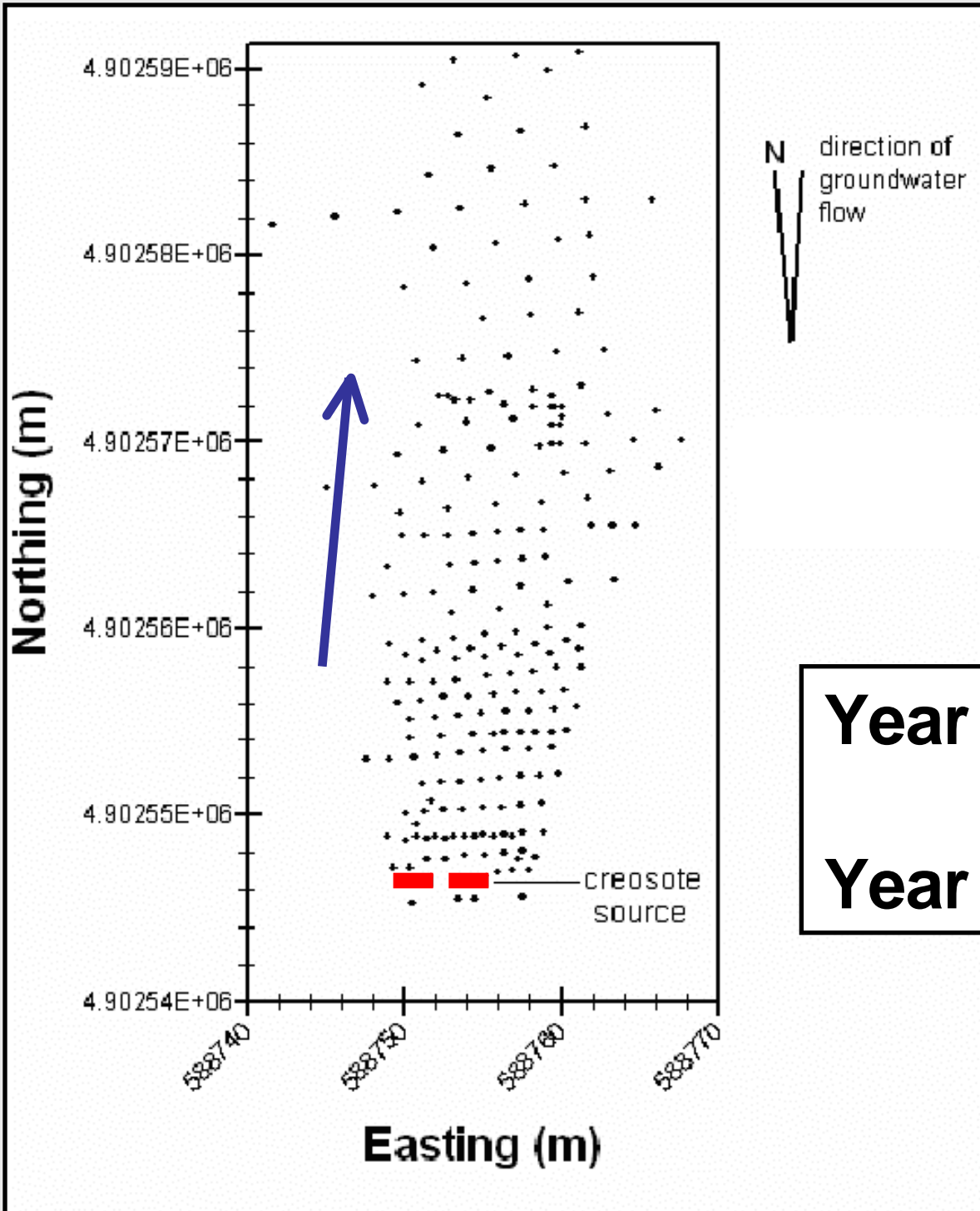

# Post-Treatment Plume Monitoring

**Year 1, 2, 4, 10 (pre)**

**Year 11, 12, 14 (post)**

# Long-Term Monitoring

Dibenzofuran - non reactive

4      10      12      14

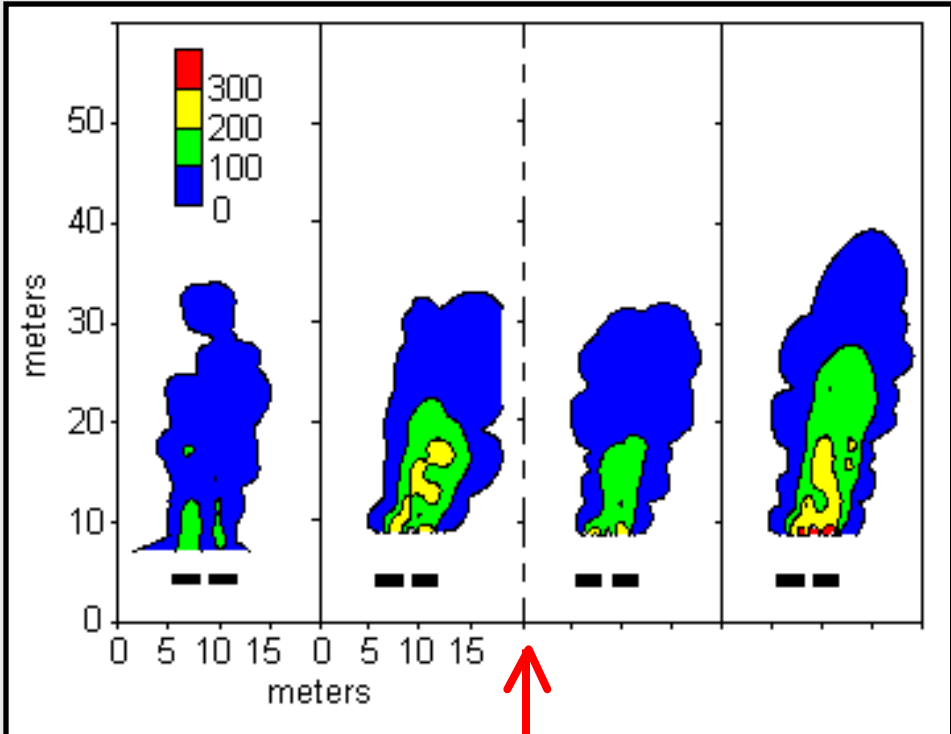

treatment

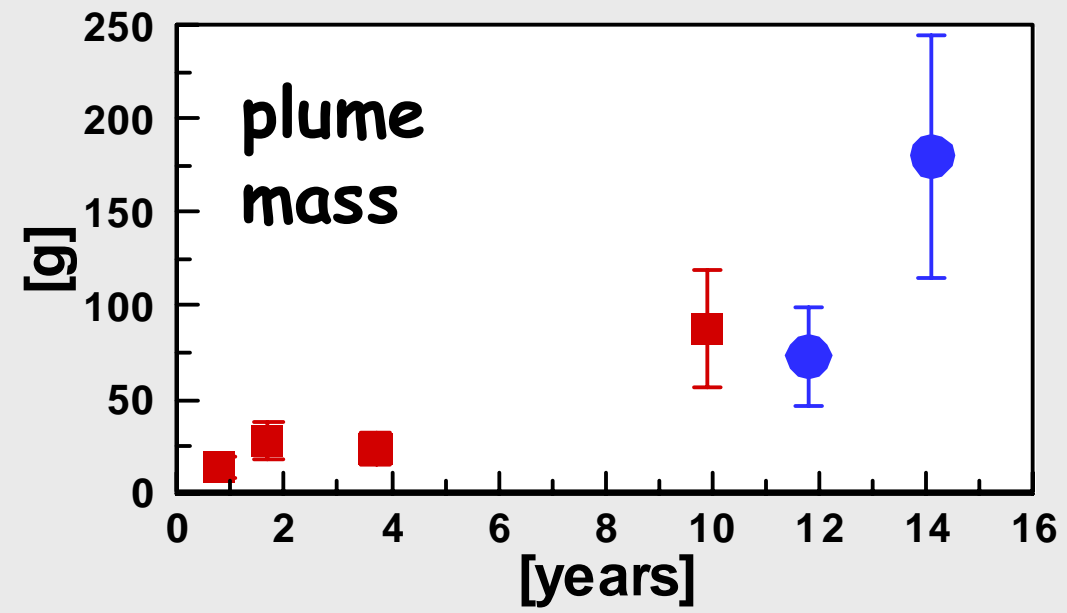
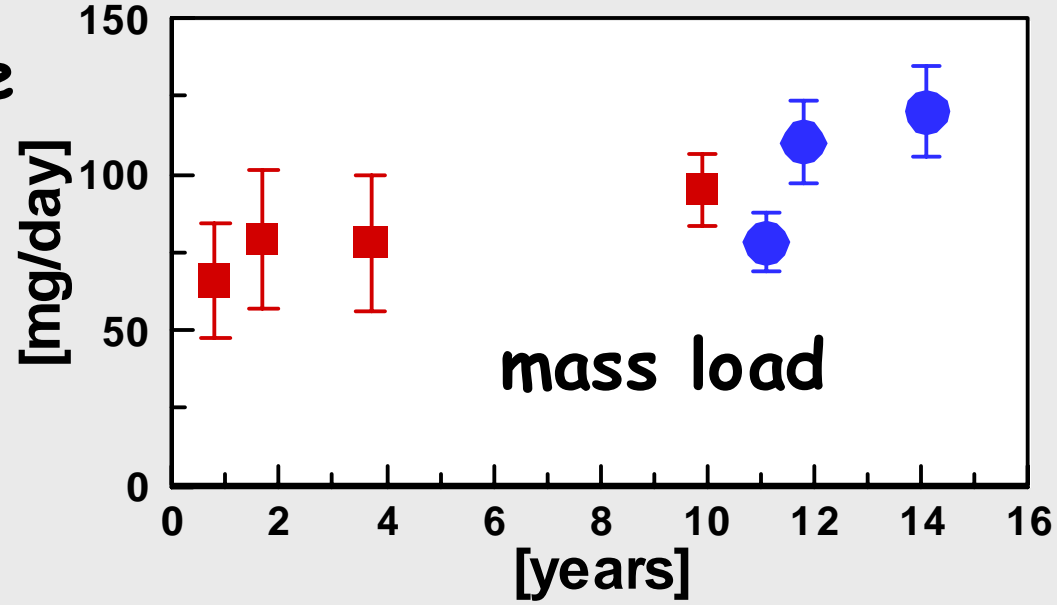

# Long-Term Monitoring

Carbazole - reactive

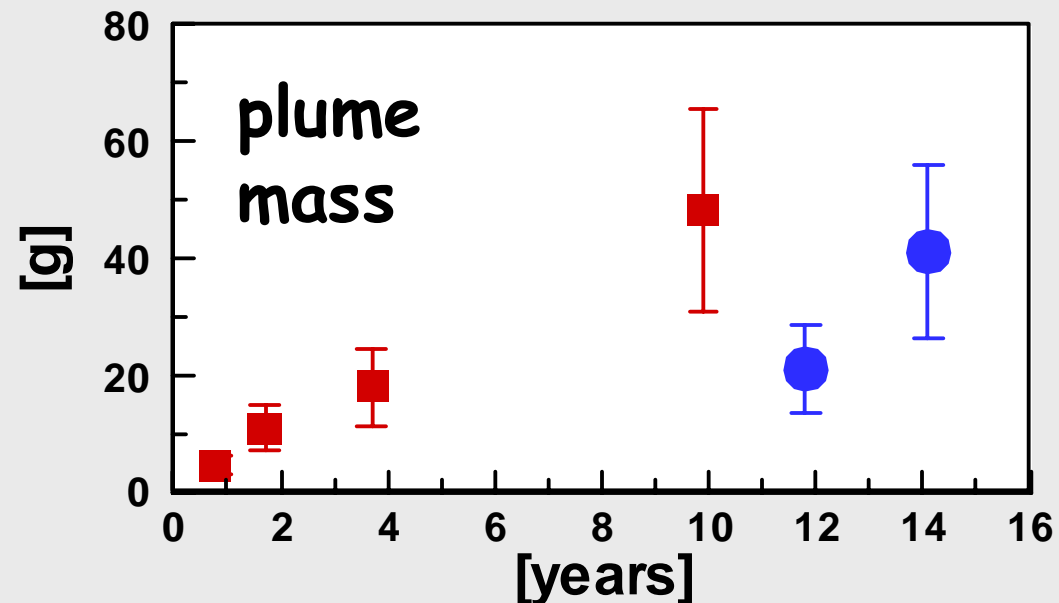
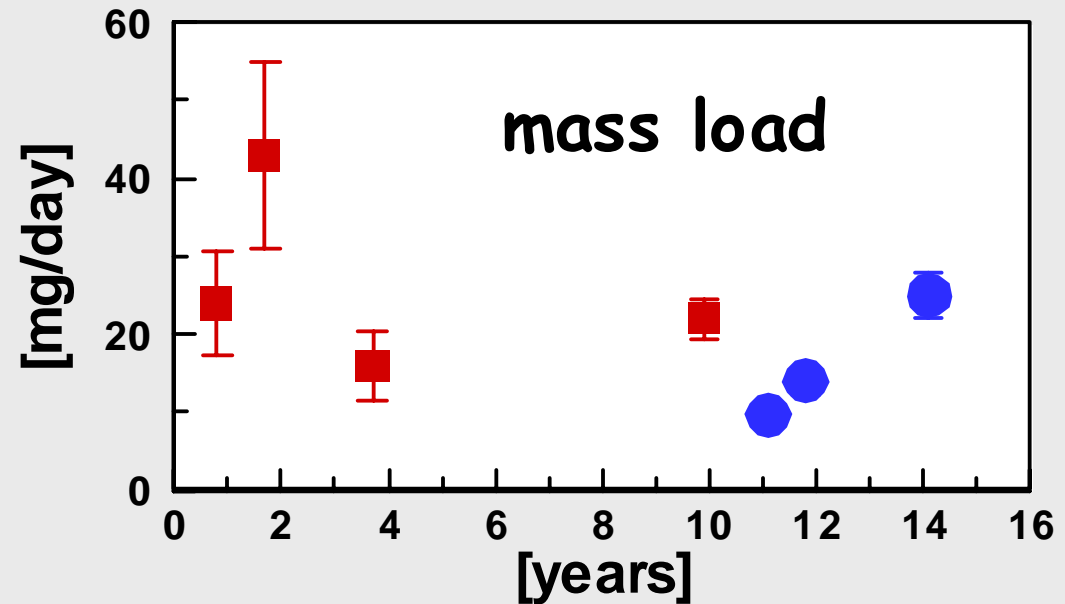
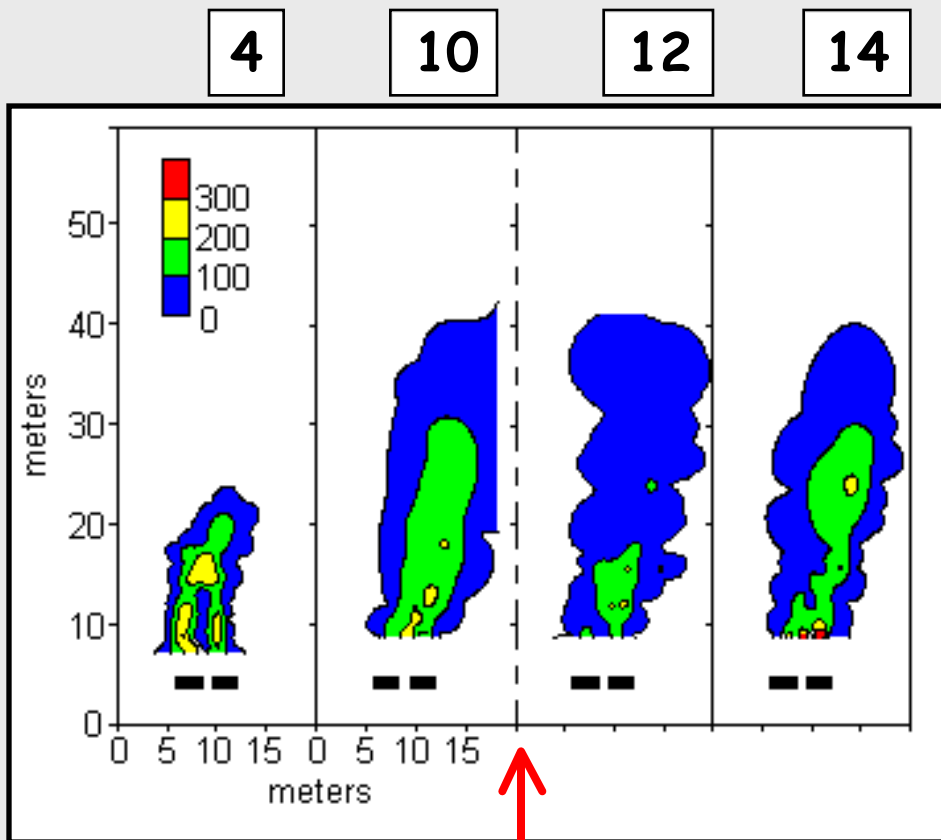

# Summary

---

- >35% reduction in mass load after 150 days for all reactive compounds
- Decrease in mass load and/or plume mass for all monitored compounds after 1 and 2 years
- Rebound in both mass load and plume mass for all monitored compounds to pre-treatment or higher levels by 4 years
- Anthracene only compound that shows continual decrease (highly sorbing;  $R \approx 20$ )

**Long-term monitoring required!!!**

# Thanks

---

- **Funding:**
    - American Petroleum Institute
    - Canadian Petroleum Products Institute
    - Natural Sciences and Engineering Research Council of Canada (NSERC)
    - Ontario Centre for Earth and Space Technology
  
  - **Lab and Field:**
    - Shirley Chatten
    - Wayne Noble
    - Marianne Vandergriendt
    - Erika Williams
    - Claudia Naas
    - Bob Ingleton
    - Paul Johnson
    - Mark Sobon
    - Bruce Stickney
- + numerous summer students